

3'-8" DECK HEIGHT ABOVE RAIL IS MEASURED AT CENTER OF CARBODY, INCLUDING CAMBER, WITH A LOAD EQUAL TO 50% OF LOAD LIMIT UNIFORMLY DISTRIBUTED OVER FULL LENGTH OF LOAD DECK

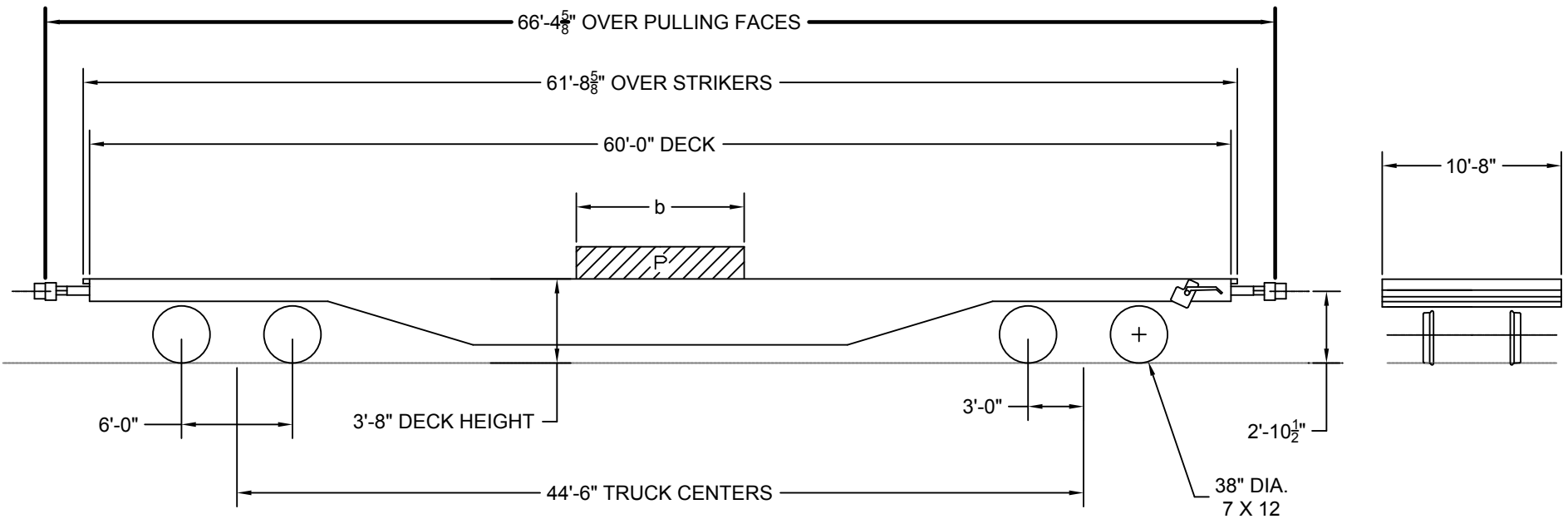

MAXIMUM WEIGHT OF PARTIAL LENGTH LOADS

LOAD LENGTH (FT) (b)	LOAD (1000) (LBS) (P)
0	205.0*
4	214.0
6	220.0
8	225.0
10	231.0
12 & OVER	LOAD LIMIT

* MAX. CONCENTRATED LOAD

CENTER OF GRAVITY - EMPTY = 24.6" ATR
 CLEARANCE PROFILE WITHIN AAR PLATE "C"

CAR NUMBER	LOAD LIMIT LBS.	LIGHT WEIGHT LBS.
131210	240,000	75,000
131211	240,000	75,000

CAR NUMBERS QTTX 131210-131211

TTX		TTX COMPANY CHICAGO, ILLINOIS	
120 TON, 60 FOOT DECK FLAT CAR			
CLASS KSH60	DATE 04-04-01	REV D	12153